

INSTALLATION INSTRUCTIONS

S4BF - 024, 036, 048, & 060 (2, 3, 4, & 5 TON) SERIES

IMPORTANT SAFETY INFORMATION	2	Air Circulation - Indoor Blower	6
AIR CONDITIONER INSTALLATION	3	System Cooling.....	6
General Information	3	System Heating (optional)	6
Before You Install this Unit.....	3	AIR CONDITIONER MAINTENANCE	7
Locating the Air Conditioner	3	REFRIGERANT CHARGING	7
Packaging Removal	3	Charging the Unit in AC mode	7
Ground Level	3	Charging Charts & Application Notes.....	8
Roof Mount	3	Figure 4. Charging Chart for 2-5 Ton Models.....	8
Connecting Refrigerant Tubing Between the Indoor & Outdoor Unit.....	4	WIRING DIAGRAMS & TABLES	9
ELECTRICAL WIRING	4	Figure 5. 2 Ton Models without CoreSense™	9
Pre-Electrical Checklist	4	Figure 6. 2 Ton Models with CoreSense™	10
Line Voltage	4	Figure 7. 3 Ton Models without CoreSense™	11
CoreSense™ Diagnostics Module	5	Figure 8. 3 Ton Models with CoreSense™	12
Compressor Protection	5	Figure 9. 4 & 5 Ton Models without CoreSense™ ..	13
Resetting Alert Codes.....	5	Figure 10. 4 & 5 Ton Models with CoreSense™	14
Grounding	5	CORESENSE TROUBLESHOOTING	15
Thermostat Connections	6	Table 3. CoreSense™ Diagnostics.....	15
START UP & ADJUSTMENTS	6	INSTALLATION CHECKLIST	20
Pre-Start Check List	6	REPLACEMENT PARTS	20
Start-Up Procedures.....	6		

IMPORTANT

ATTENTION INSTALLERS:

It is your responsibility to know this product better than your customer. This includes being able to install the product according to strict safety guidelines and instructing the customer on how to operate and maintain the equipment for the life of the product. Safety should always be the deciding factor when installing this product and using common sense plays an important role as well. Pay attention to all safety warnings and any other special notes highlighted in the manual. Improper installation of the furnace or failure to follow safety warnings could result in serious injury, death, or property damage.

These instructions are primarily intended to assist qualified individuals experienced in the proper installation of this appliance. Some local codes require licensed installation/service personnel for this type of equipment. Please read all instructions carefully before starting the installation. Return these instructions to the customer's package for future reference.

DO NOT DESTROY. PLEASE READ CAREFULLY & KEEP IN A SAFE PLACE FOR FUTURE REFERENCE.

IMPORTANT SAFETY INFORMATION

INSTALLER: Please read all instructions before servicing this equipment. Pay attention to all safety warnings and any other special notes highlighted in the manual. Safety markings are used frequently throughout this manual to designate a degree or level of seriousness and should not be ignored.

WARNING indicates a potentially hazardous situation that if not avoided, could result in personal injury or death.

CAUTION indicates a potentially hazardous situation that if not avoided, may result in minor or moderate injury or property damage.

WARNING:

ELECTRICAL SHOCK, FIRE OR EXPLOSION HAZARD

Failure to follow safety warnings exactly could result in serious injury or property damage.

Improper servicing could result in dangerous operation, serious injury, death or property damage.

- Before servicing, disconnect all electrical power to the equipment.
- When servicing controls, label all wires prior to disconnecting. Reconnect wires correctly.
- Verify proper operation after servicing.

WARNING:

This split system air conditioner is shipped charged with R410A refrigerant and ready for installation. If repairs make it necessary for evacuation and charging, it should only be attempted by qualified trained personnel thoroughly familiar with this equipment. Under no circumstances should the owner attempt to install and/or service this equipment. Failure to comply with this warning could result in property damage, personal injury, or death.

CAUTION:

This unit uses R-410A refrigerant. **DO NOT** use any other refrigerant in this unit. Use of another refrigerant will damage the unit.

WARNING:

Unless noted otherwise in these instructions, only factory authorized parts or accessory kits may be used with this product. Improper installation, service, adjustment, or maintenance may cause explosion, fire, electrical shock or other hazardous conditions which may result in personal injury or property damage

WARNING:

The information listed below and the next page must be followed during the installation, service, and operation of this furnace. Failure to follow safety recommendations could result in possible damage to the equipment, serious personal injury or death.

- The installer must comply with all local codes and regulations which govern the installation of this type of equipment. Local codes and regulations take precedence over any recommendations contained in these instructions. Consult local building codes and the National Electrical Code (ANSI CI) for special installation requirements.
- All electrical wiring must be completed in accordance with local, state and national codes and regulations and with the National Electric Code (ANSI/NFPA 70) or in Canada the Canadian Electric Code Part 1 CSA C.22.1.
- This equipment contains liquid and gaseous refrigerant under high pressure. **DO NOT USE ANY PORTION OF THE CHARGE FOR PURGING OR LEAK TESTING.** Installation or servicing should only be performed by qualified trained personnel thoroughly familiar with this type equipment.
- Fully annealed, refrigerant grade copper tubing should be used when installing the system. Refrigerant suction line tubing should be fully insulated.
- Installation of equipment may require brazing operations. Installer must comply with safety codes and wear appropriate safety equipment (safety glasses, work gloves, fire extinguisher, etc.) when performing brazing operations.
- Follow all precautions in the literature, on tags, and on labels provided with the equipment. Read and thoroughly understand the instructions provided with the equipment prior to performing the installation and operational checkout of the equipment.
- Refrigerant and electrical line should be routed through suitably waterproofed openings to prevent water from leaking into the structure.

AIR CONDITIONER INSTALLATION

General Information

The S4BF series air conditioner is designed only for outdoor rooftop or ground level installations. This unit has been tested for capacity and efficiency in accordance with AHRI Standards and will provide many years of safe and dependable comfort, providing it is properly installed and maintained. Abuse, improper use, and/or improper maintenance can shorten the life of the appliance and create unsafe hazards.

To achieve optimum performance and minimize equipment failure, it is recommended that periodic maintenance be performed on this unit. The ability to properly perform maintenance on this equipment requires certain mechanical skills and tools.

Before You Install this Unit

- ✓ The cooling load of the area to be conditioned must be calculated and a system of the proper capacity selected. It is recommended that the area to be conditioned be completely insulated and vapor sealed.
- ✓ Check the electrical supply and verify the power supply is adequate for unit operation. The system must be wired and provided with circuit protection in accordance with local building codes. If there is any question concerning the power supply, contact the local power company.
- ✓ The indoor section (air handler, furnace, etc) should be installed before routing the refrigerant tubing. Refer to the indoor unit's installation instructions for installation details.
- ✓ All units are securely packed at the time of shipment and upon arrival should be carefully inspected for damage prior to installing the equipment at the job site. Verify coil fins are straight. If necessary, comb fins to remove flattened or bent fins. Claims for damage (apparent or concealed) should be filed immediately with the carrier.
- ✓ Please consult your dealer for maintenance information and availability of maintenance contracts. Please read all instructions before installing the unit.

Locating the Air Conditioner

- Survey the job site to determine the best location for mounting the outdoor unit.
- The outdoor unit should be installed no closer than 18 inches from the outside walls of the facility and in an area free from overhead obstructions to ensure unrestricted airflow through the outdoor unit.
- Sufficient clearance for unobstructed airflow through the outdoor coil must be maintained in order to achieve rated performance. See Figure 1 for minimum clearances to obstructions.
- Overhead obstructions (Figure 1), poorly ventilated areas, and areas subject to accumulation of debris should be avoided.
- Consideration should be given to availability of electric power, service access, noise, and shade.

Packaging Removal

NOTE: To prevent damage to the tubing connections, carefully remove the carton and user's manual from the equipment. Discard the shipping carton.

Ground Level

Ground level installations must be located according to local building codes or ordinances and these requirements:

- Clearances must be in accordance with those shown in Figure 1.
- A suitable mounting pad (Figure 1) must be provided and separate from the building foundation. The pad must be level and strong enough to support the weight of the unit. The slab height must be a minimum of 2" (5 cm) above grade and with adequate drainage.

Roof Mount

- The method of mounting should be designed so that it does not overload roof structures or transmit noise to the interior of the structure. The roof must be structurally capable of handling the weight of the unit.
- Full perimeter support is required under the unit. Support must be made of weather resistant materials and installed prior to unit installation.
- The support must be built to raise the unit 6" above the roof.

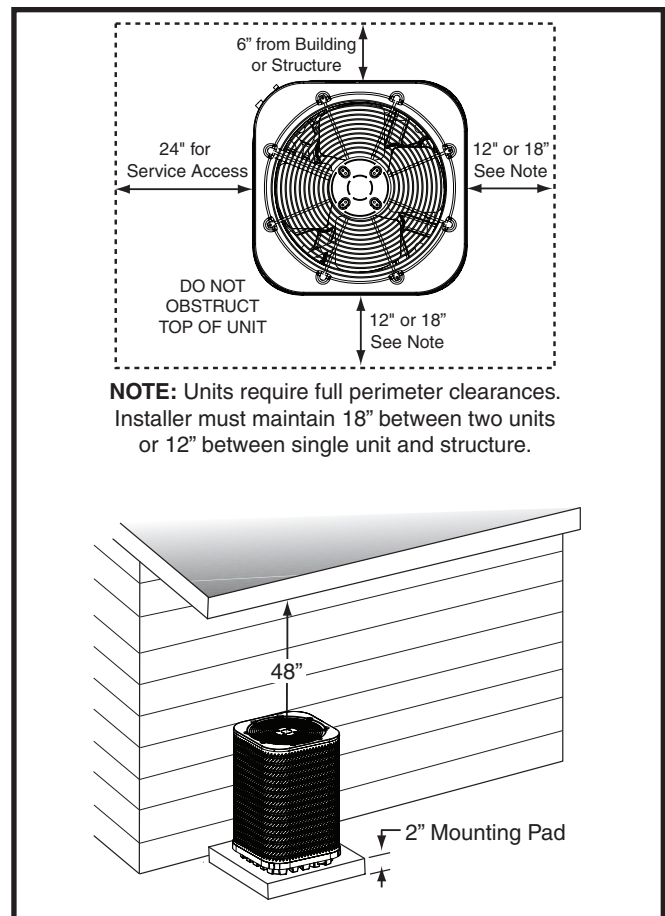

Figure 1. Clearance Requirements

Connecting Refrigerant Tubing Between the Indoor & Outdoor Unit

CAUTION:

When servicing, cover or seal openings to minimize the exposure of the refrigerant system to air to prevent accumulation of moisture and other contaminants.

After outdoor and indoor unit placement has been determined, route refrigerant tubing between the equipment in accordance with sound installation practices.

- When connecting refrigerant linesets together, it is recommended that dry nitrogen be flowing through the joints during brazing to prevent internal oxidation and scaling.
- Refrigerant tubing should be routed in a manner that minimizes the length of tubing and the number of bends in the tubing. If precise forming of refrigerant lines is required, a copper tubing bender is recommended. Avoid sharp bends and contact of the refrigerant lines with metal surfaces.
- Refrigerant tubing should be supported in a manner that the tubing will not vibrate or abrade during system operation.
- Tubing should be kept clean of foreign debris during installation.
- Every effort should be made by the installer to ensure that the field installed refrigerant containing components of the system have been installed in accordance with these instructions and sound installation practices to insure reliable system operation and longevity.
- The maximum recommended interconnecting refrigerant line lengths is 75 ft. and the vertical elevation difference between the indoor and outdoor sections should not exceed 20 ft.

COPPER WIRE SIZE — AWG (1% VOLTAGE DROP)				
SUPPLY WIRE LENGTH-FEET				SUPPLY CIRCUIT AMPACITY
200	150	100	50	
6	8	10	14	15
4	6	8	12	20
4	6	8	10	25
4	4	6	10	30
3	4	6	8	35
3	4	6	8	40
2	3	4	6	45
2	3	4	6	50
2	3	4	6	55
1	2	3	4	60

Wire Size based on N.E.C. for 60° type copper conductors.

Table 1. Copper Wire Size

- A filter dryer is provided with the unit and must be installed in the liquid line of the system. If the installation replaces a system with a filter dryer already present in the liquid line, the filter dryer must be replaced with the one supplied with the unit. The filter dryer must be installed in strict accordance with the manufacturer's installation instructions.
- Optional equipment such as liquid line solenoid valves, low ambient, etc., should be installed in strict accordance with the manufacturer's installation instructions.

ELECTRICAL WIRING

WARNING:

To avoid risk of electrical shock, personal injury, or death, disconnect all electrical power to the unit before performing any maintenance or service. The unit may have more than one electrical supply.

Label all wires prior to disconnection when servicing the unit. Wiring errors can cause improper and dangerous operation.

- All electrical connections must be in compliance with all applicable local codes and ordinances, and with the current revision of the National Electric Code (ANSI/NFPA 70).
- For Canadian installations the electrical connections and grounding shall comply with the current Canadian Electrical Code (CSA C22.1 and/or local codes).

Pre-Electrical Checklist

- ✓ Verify that the voltage, frequency, and phase of the supply source match the specifications on the unit rating plate.
- ✓ Verify that the service provided by the utility is sufficient to handle the additional load imposed by this equipment. Refer to the unit wiring label for proper voltage wiring.
- ✓ Verify factory wiring is in accordance with the unit wiring diagram See [Figure 5, \(page 9\)](#), [Figure 6, \(page 10\)](#), [Figure 7, \(page 11\)](#), [Figure 8, \(page 12\)](#), [Figure 9, \(page 13\)](#), [Figure 10, \(page 14\)](#). Inspect for loose connections.

Line Voltage

- A wiring diagram is located on the inside cover of the electrical box of the outdoor unit. The installer should become familiar with the wiring diagram before making any electrical connections to the outdoor unit.
- **An electrical disconnect must be located within sight of and readily accessible to the unit.** This switch shall be capable of electrically de-energizing the outdoor unit.
- Line voltage to the unit should be supplied from a dedicated branch circuit containing the correct fuse or circuit breaker for the unit. Incoming field wiring and minimum size of electrical conductors and circuit

protection must be in compliance with information listed on the outdoor unit data label. Any other wiring methods must be acceptable to authority having jurisdiction.

- The outdoor unit requires both power and control circuit electrical connections. Refer to the wiring diagram / schematic for identification and location of outdoor unit field wiring interfaces See [Figure 5, \(page 9\)](#), [Figure 6, \(page 10\)](#), [Figure 7, \(page 11\)](#), [Figure 8, \(page 12\)](#), [Figure 9, \(page 13\)](#), [Figure 10, \(page 14\)](#). Make all electrical connections in accordance with all applicable codes and ordinances.
- Overcurrent protection must be provided at the branch circuit distribution panel and sized as shown on the unit rating label and according to applicable local codes. See the unit rating plate for minimum circuit ampacity and maximum overcurrent protection limits.
- Provide power supply for the unit in accordance with the unit wiring diagram, and the unit rating plate. Connect the line-voltage leads to the terminals on the contactor inside the control compartment.
- Use only copper wire for the line voltage power supply to this unit as listed in [Table 1, \(page 4\)](#). Use proper code agency listed conduit and a conduit connector for connecting the supply wires to the unit. Use of rain tight conduit is recommended.
- 208/230 Volt units are shipped from the factory wired for 230 volt operation. For 208V operation, remove the lead from the transformer terminal marked 240V and connect it to the terminal marked 208V.
- Optional equipment requiring connection to the power or control circuits must be wired in strict accordance of the NEC (ANSI/NFPA 70), applicable local codes, and the instructions provided with the equipment.

CoreSense™ Diagnostics Module

(Select Models Only)

The CoreSense™ Diagnostics Module ([Figure 2](#)) is a breakthrough innovation for troubleshooting heat pump and air conditioning system failures. The module installs easily in the electrical box of the outdoor unit near the compressor contactor. By using the compressor as a sensor, CoreSense Diagnostics helps the service technician more accurately troubleshoot system and compressor fault conditions.

A flashing LED indicator communicates the ALERT code and a diagnostic key is also imprinted on the side of the module to quickly direct the technician to the root cause of a problem. Alert identification codes are also listed in [Table 3, \(page 15\)](#).

Compressor Protection

The CoreSense™ Diagnostics module utilizes proprietary algorithms to protect the compressor and system from repeated trips of system pressure controls and the compressor internal overload. The protection terminal of the module should be wired in series with the system low pressure and high pressure cutouts, as well as the compressor contactor. When the module detects a series of trips as described below, it will activate a lockout feature that opens the normally closed protection contacts in the module, thereby cutting power to the contactor and shutting off the compressor.

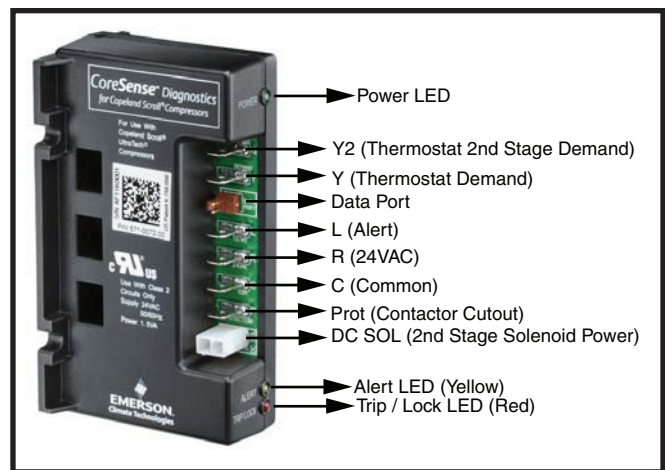

Figure 2. CoreSense™ Diagnostics Module

Resetting Alert Codes

When the CoreSense™ Diagnostics module has detected a series of adverse conditions that have caused it to lockout the compressor, and after the issue has been resolved, it is necessary to manually reset the module in order to clear the present alert code.

The primary way of clearing the code and resetting the alert is to press the reset button located on the module.

NOTE: Pressing the reset will require a pin or a mini electronics screwdriver. This button must be pressed and held for a minimum of one second for the module to be reset. Pressing the reset button clears the immediate lock code and the seven day operating history. It will not clear the permanent module history. In the case of the three-wire module, the codes can be reset or cleared by cycling power to the module. This can be done by disengaging the Common (C) terminal. This will not clear the seven day operating history.

Grounding

WARNING:

The unit cabinet must have an uninterrupted or unbroken electrical ground to minimize personal injury if an electrical fault should occur. Do not use gas piping as an electrical ground!

This unit must be electrically grounded in accordance with local codes or, in the absence of local codes, with the National Electrical Code (ANSI/NFPA 70) or the CSA C22.1 Electrical Code. Use the grounding lug provided in the control box for grounding the unit.

Thermostat Connections

- Thermostat connections should be made in accordance with the instructions supplied with the thermostat and the indoor equipment. Typical AC and thermostat hookups are shown in [Figure 3, \(page 6\)](#).
- The outdoor unit is designed to operate from a 24 VAC Class II control circuit. The control circuit wiring must comply with the current provisions of the NEC (ANSI/NFPA 70) and with applicable local codes having jurisdiction.
- The low voltage wires must be properly connected to the units low voltage terminal block. Recommended wire gauge and wire lengths for typical thermostat connections are listed in [Table 2](#).
- The thermostat should be mounted about 5 feet above the floor on an inside wall. DO NOT install the thermostat on an outside wall or any other location where its operation may be adversely affected by radiant heat from fireplaces, sunlight, or lighting fixtures, and convective heat from warm air registers or electrical appliances. Refer to the thermostat manufacturer's instruction sheet for detailed mounting and installation information.

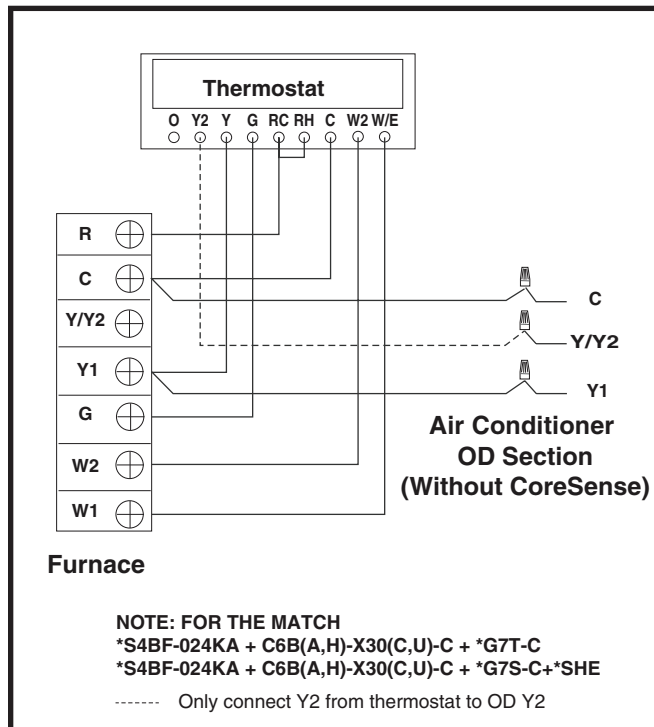

Figure 3. Typical 2-Stage Air Conditioner (without CoreSense) with Gas Furnace

THERMOSTAT WIRE GAUGE	MAXIMUM RECOMMENDED THERMOSTAT WIRE LENGTH (FT)
24	25
22	45
20	70
18	110

Table 2. Thermostat Wire Gauge

START UP & ADJUSTMENTS

Pre-Start Check List

- ✓ Verify the indoor unit is level and allows proper condensate drainage.
- ✓ Verify the outdoor coil and top of the unit are free from obstructions and debris, and all equipment access/control panels are in place.
- ✓ Verify air filters are cleaned and properly installed.
- ✓ Verify duct work is sealed to prevent air leakage.
- ✓ Verify line voltage power leads are securely connected and the unit is properly grounded.
- ✓ Verify low voltage wires are securely connected to the correct leads on the low voltage terminal strip.
- ✓ Verify power supply branch circuit overcurrent protection is sized properly.
- ✓ Verify the thermostat is wired correctly.

Start-Up Procedures

The thermostat's function mode should be set to OFF and the fan mode should be set to AUTO. Close all electrical disconnects to energize the system.

Air Circulation - Indoor Blower

1. Set the thermostat system mode on OFF and the fan mode to ON.
2. Verify the blower runs continuously. Check the air delivery at the supply registers and adjust register openings for balanced air distribution. If insufficient air is detected, examine ductwork for leaks or obstructions.
3. Set the thermostat fan mode to AUTO and verify the blower stops running.

System Cooling

1. Set the thermostat's system mode to COOL and the fan mode to AUTO. Gradually lower the thermostat temperature setpoint below room temperature and verify the outdoor unit and indoor blower energize.
2. Verify blower wheel is spinning in direction indicated by arrow. Feel the air being circulated by the indoor blower and verify that it is cooler than ambient temperature. Listen for any unusual noises. If unusual sounds occur, determine the source of the noise and correct as necessary.
3. Verify HI and LO refrigerant pressures.
4. Allow the system to operate for several minutes and then set the temperature selector above room temperature. Verify the fan and compressor cycle off with the thermostat. **NOTE:** The blower should also stop unless fan mode is set to the ON position.

System Heating (optional)

1. Set the thermostat's system mode to HEAT and the temperature mode above room temperature.
2. Verify the optional heating equipment (furnace or electric heat) and indoor blower energize. Feel the air being circulated by the indoor blower and verify that it is warmer than ambient temperature. Listen for any unusual noises. If unusual sounds occur, determine the source of the noise and correct as necessary.

AIR CONDITIONER MAINTENANCE

WARNING:

To prevent electrical shock, personal injury, or death, disconnect all electrical power to the unit before performing any maintenance or service. The unit may have more than one electrical supply.

Proper maintenance is important to achieve optimum performance from the air conditioner. The ability to properly perform maintenance on this equipment requires certain mechanical skills and tools. If you do not possess these skills, contact your dealer for maintenance. Consult your local dealer about the availability of maintenance contracts. Routine maintenance should include the following:

- Inspect and clean or replace air filters at the beginning of each heating and cooling season, or more frequently if required.
- Inspect the condensate drain and outdoor coil at the beginning of each cooling season. Remove any debris. Clean the outdoor coil and louvers as necessary using a mild detergent and water. Rinse thoroughly with water.
- Inspect the electrical connections for tightness at the beginning of each heating and cooling season. Service as necessary.

CAUTION:

The unit should never be operated without a filter in the return air system. Replace disposable filters with the same type and size.

- Do not attempt to add additional oil to motors unequipped with oil tubes. The compressor is hermetically sealed at the factory and does not require lubrication.

REFRIGERANT CHARGING

WARNING:

S4BF Split System Air Conditioners are shipped charged with R410A refrigerant and ready for installation. If repairs make it necessary for evacuation and charging, it should only be attempted by qualified trained personnel thoroughly familiar with this equipment. Under no circumstances should the owner attempt to install and/or service this equipment. Failure to comply with this warning could result in property damage, personal injury, or death.

After refrigerant line connections are completed, it is required that you leak check and evacuate the indoor section and all line connections (using proper methods) before finalizing the full system refrigerant charge.

- Refrigerant charging charts are applicable only to matched assemblies of NORDYNE equipment and listed airflows for the indoor coil. Refer to [Figure 4, \(page 8\)](#) for correct system charging.
- S4BF outdoor units with non-AHRI listed indoor coils are not recommended. Deviations from rated airflows or non-listed combinations may require modification to the expansion device and refrigerant charging procedures for proper and efficient system operation.
- The refrigerant charge can be checked and adjusted through the service ports provided external to the outdoor unit. Use only gage line sets which have a “Schrader” depression device present to actuate the valve.
- A high-pressure switch is factory-installed and located in the liquid line internal to the outdoor unit. The switch is designed to protect the system when very high pressures occur during abnormal conditions. Under normal conditions, the switch is closed. If the liquid pressure rises above 575 psig, then the switch will open and de-energize the outdoor unit. The switch will close again once the liquid pressure decreases to 460 psig. Please note that the switch interrupts the thermostat inputs to the unit. Thus, when the switch opens and then closes, there may be a 5 minute short cycling delay before the outdoor unit will energize.
- On select models a low-pressure switch is factory-installed and located in the suction line internal to the outdoor unit. The switch is designed to protect the compressor from a loss of charge. Under normal conditions, the switch is closed. If the suction pressure falls below 5 psig, then the switch will open and de-energize the outdoor unit. The switch will close again once the suction pressure increases above 20 psig. Please note that the switch interrupts the thermostat inputs to the unit. When the switch opens and then closes, there will be a 5 minute short cycling delay before the outdoor unit will energize.

Charging the Unit in AC mode

(At outdoor temperatures above 55° F for optimized sub-cooling of 10° F - 12° F.)

1. With the system operating at steady-state, measure the liquid refrigerant pressure (in psig) at the outdoor unit service valve.
 2. Measure the liquid refrigerant temperature (in Fahrenheit) at the service valve.
 3. Determine the required liquid refrigerant pressure from the appropriate charging chart. See [Figure 4, \(page 8\)](#).
- If the pressure measured in Step 1 is greater than the required liquid refrigerant pressure determined in Step 3, then there is too much charge in the system. Remove refrigerant and repeat Steps 1 through 3 until the system is correctly charged.
 - If the pressure measured in Step 1 is less than the required liquid refrigerant pressure determined in Step 3, there is too little charge in the system. Add refrigerant and repeat Steps 1 through 3 until the system is correctly charged.

Charging Charts & Application Notes

- This equipment's cooling system contains refrigerant under high pressure. Always use safe and environmentally sound methods when handling refrigerant handling or servicing the unit. Review the factory literature and safety warnings prior to servicing.
- When repairing system leaks, always use a nitrogen (inert) gas to protect the refrigerant system and pressure check the repair before re-charging. Always replace the filter-dryers when performing any repair to the refrigeration system with one capable of acid removal. After completing the repairs, evacuate the system to 350 - 500 microns and weigh in the refrigerant to the amount specified on the unit rating label.
- Charging charts are valid for a variety of indoor, return air conditions and are most influenced by the outdoor ambient temperature, outdoor fan operation and the unit operating voltage. Before using these charts, make sure the unit is in a stable operating mode. As shown in the charging chart (Figure 4), the ideal system sub-cooling can vary over the range of operation. Reference the charts to determine the ideal amount of sub-cooling for a given liquid pressure. Units charged to other values will not perform at the rated unit efficiency (EER) or rated Coefficient of Performance (COP) in heating mode.
- To inspect a systems operation using quality instruments, match the measured liquid temperature to the units chart. The measured liquid pressure reading should be within 3% of the charts value for most installations.
- For systems that are operating with more than a 5% deviation, inspect the unit for the proper voltage and phase balance and the refrigeration system for leaks.
- Units that are operating at less than 95% of the nominal voltage or with a 2% phase imbalance may see a more significant deviation than the amount stated above.
- **DONOT** use the charts in systems that have a fan cycling under low-ambient control. Refer to the low-ambient kit instructions for more information. (If applicable)

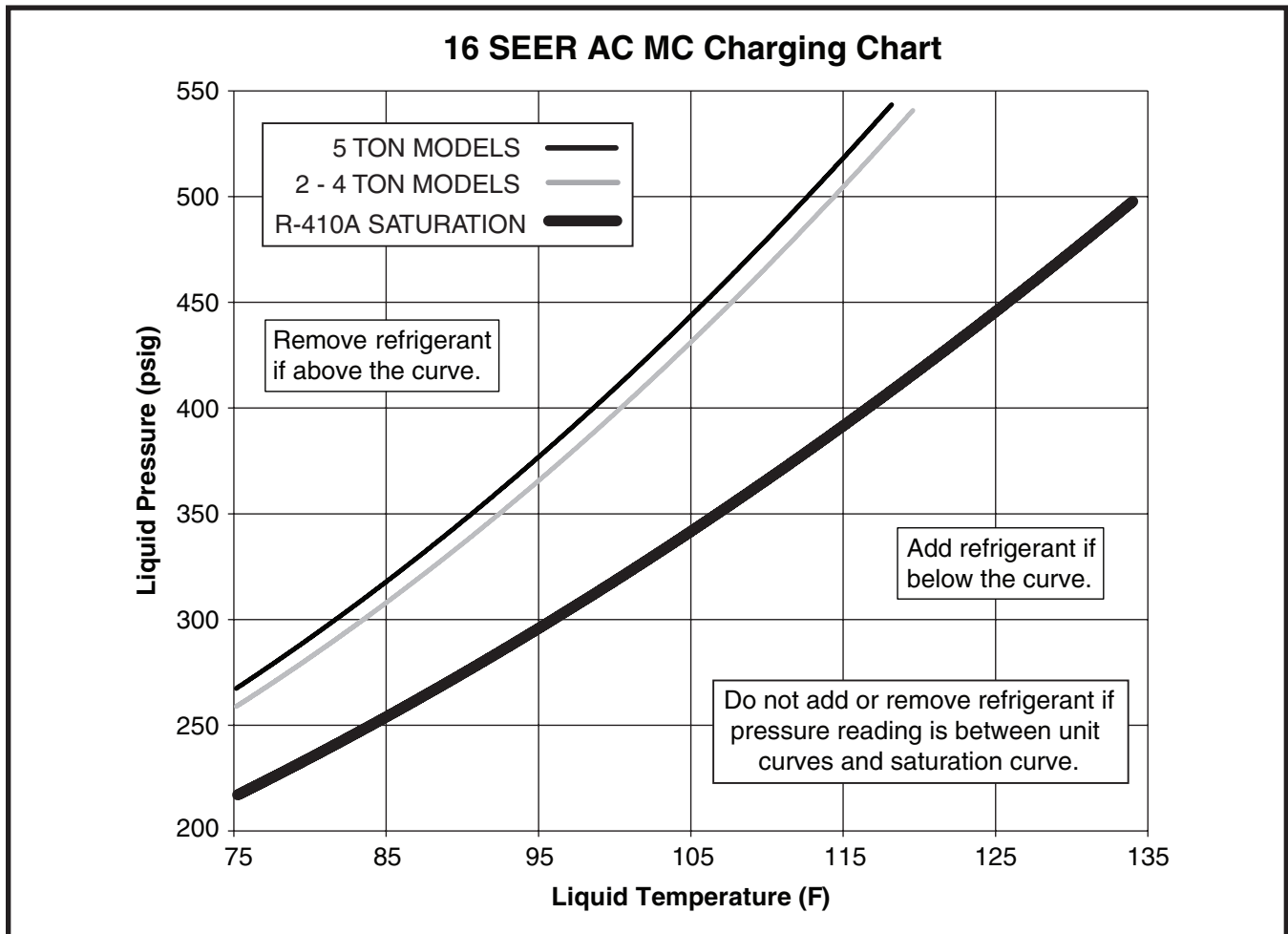

Figure 4. Charging Chart for 2-5 Ton Models

WIRING DIAGRAM

Two Stage Split System Air Conditioner (Outdoor Section) With Single Speed Fan Motor

208/230V

Single Phase / 60 Hz.

NOTES:

1. Disconnect all power before servicing.
2. For supply connections use copper conductors only.
3. Not suitable on systems that exceed 150 volts to ground.
4. For replacement wires use conductors suitable for 105 °C
5. For ampacities and overcurrent protection, see unit rating plate.
6. Connect to 24 vac/40v/class 2 circuit. See furnace/airhandler installation instructions for control circuit and optional relay/transformer kits.

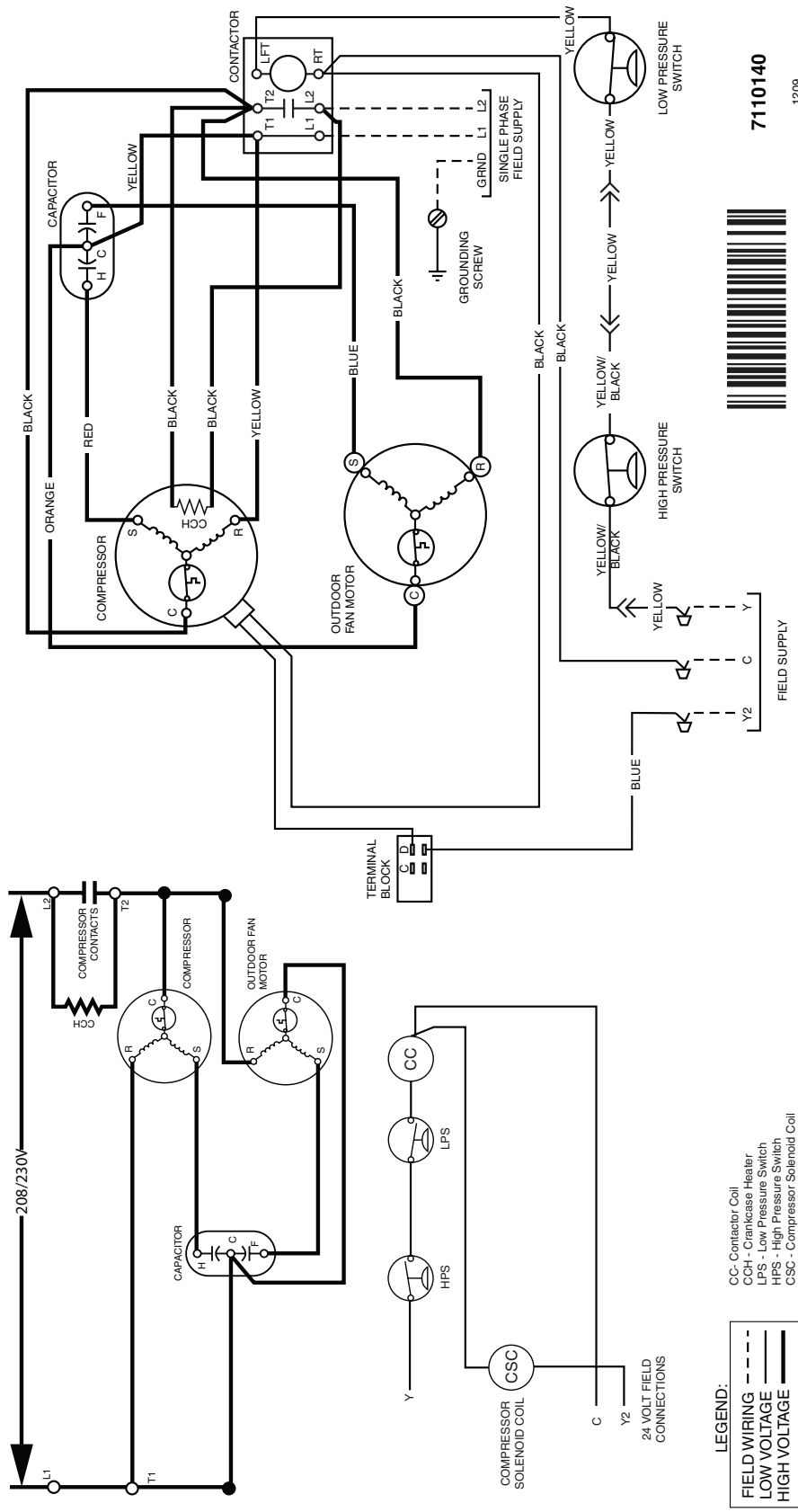

- LEGEND:**
- FIELD WIRING
 - LOW VOLTAGE
 - HIGH VOLTAGE
- CC - Contactor Coil
 CCH - Crankcase Heater
 LPS - Low Pressure Switch
 HPS - High Pressure Switch
 CSC - Compressor Solenoid Coil



7110140

12/08

Figure 5. W.D. for 2 Ton Models without CoreSense™

WIRING DIAGRAM

Two Stage Split System Air Conditioner (Outdoor Section) With Single Speed Fan Motor

208/230V

Single Phase / 60 Hz.

Status LED	Status LED Description	Lockout Level	Lockout Indication
Normal Run, Solid Green	Normal Operation, no trip	N/A	N/A
Code 1; Yellow Flash 1	Compressor running extremely long run cycle. (disabled in HP mode.)	N/A	N/A
Code 2; Yellow Flash 2	Compressor Pressure Trip. Disch. or supt. pressure out of limits or compressor overloaded.	4 cons, 10x total	Red: Flash 2
Code 3; Yellow Flash 3	Short Cycling. Compressor is running only briefly.	4 cons, 10x total	Red: Flash 3
Code 4; Yellow Flash 4	Locked Rotor.	10 consecutive	Red: Flash 4
Code 5; Yellow Flash 5	Compressor Moderate Run. Compressor runs >15min, then trips >7min.	4 cons, 10x total	Red: Flash 5
Code 6; Red Flash 6	Open Start Circuit. Current only in run circuit.	1 Occurrence	Red: Flash 6
Code 7; Red Flash 7	Open Start Circuit. Current only in start circuit.	1 Occurrence	Red: Flash 7
Code 8; Yellow Flash 8	Welded Contactor. Compressor always runs.	N/A	N/A
Code 9; Yellow Flash 9	Low Voltage. Control circuit <17 VAC.	N/A	N/A
Code 10; Red Flash 10	Over Current Protection. PROT terminal has >2A input for more than 40ms	1 Occurrence	Red: Flash 10

- NOTES:**
1. Disconnect all power before servicing.
 2. For supply connections use copper conductors only.
 3. Not suitable on systems that exceed 150 volts to ground.
 4. For replacement wires use conductors suitable for 105 °C
 5. For ampacities and overcurrent protection, see unit rating plate.
 6. Connect to 24 vac/40va/class 2 circuit. See furnace/airhandler installation instructions for control circuit and optional relay/transformer kits.
 7. Couper le courant avant de faire l'entretien.
 8. Employez uniquement des conducteurs en cuivre.
 9. Ne convient pas aux installations de plus de 150 volt a la terre.

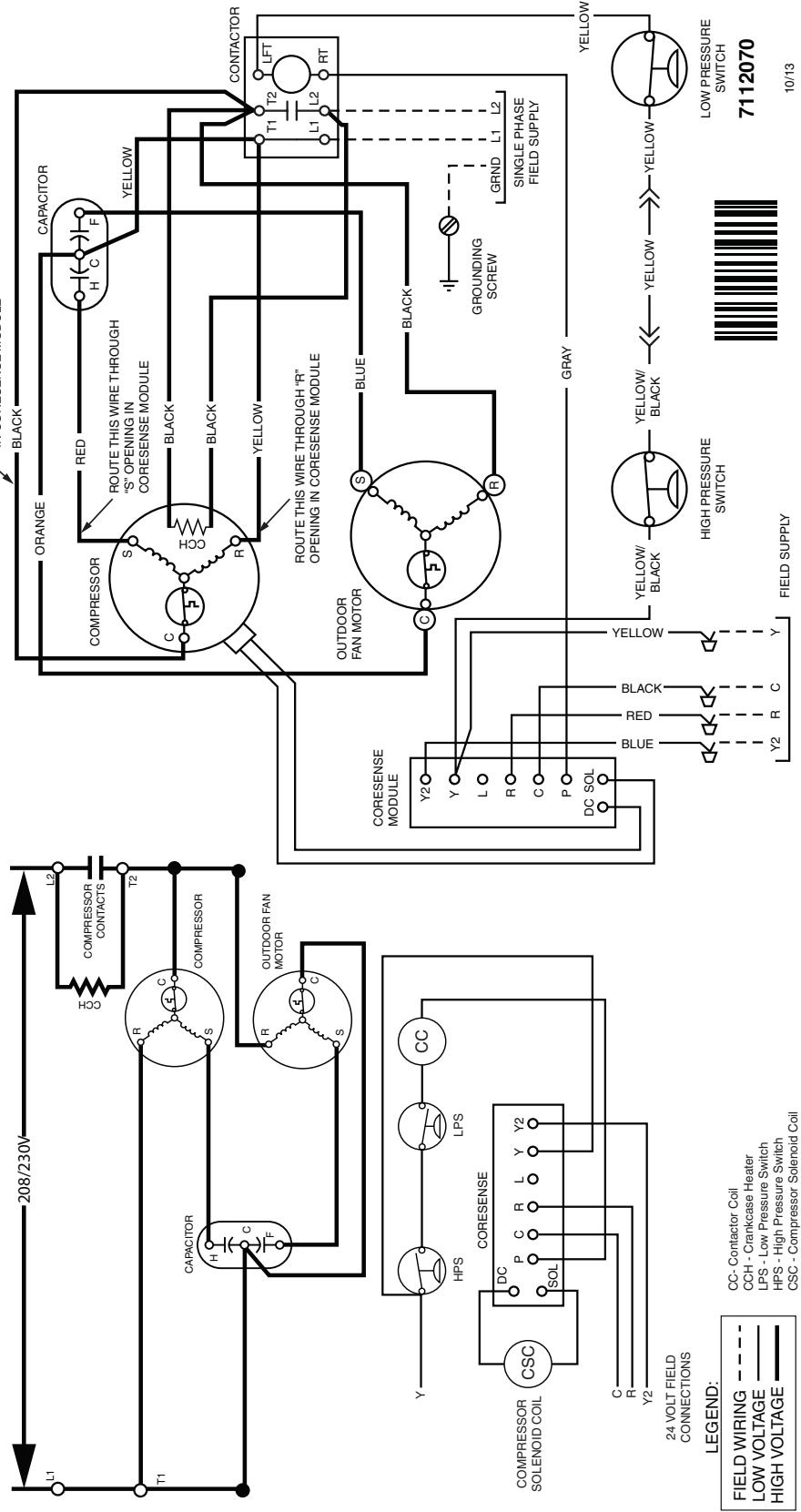

Figure 6. W.D. for 2 Ton Models with CoreSense™

WIRING DIAGRAM

Two Stage Split Air Conditioner (Outdoor Section) With Two Speed Outdoor Fan Motor

208/230V

Single Phase / 60 Hz.

NOTES:

1. Disconnect all power before servicing.
2. For supply connections use copper conductors only.
3. Not suitable on systems that exceed 150 volts to ground.
4. For replacement wires use conductors suitable for 105
5. For ampacities and overcurrent protection, see unit rating plate.
6. Connect to 24 vac/40va/class 2 circuit. See furnace/airhandler installation instructions for control circuit and optional relay/transformer kits.

1. Couper le courant avant de faire letrien.
2. Employez uniquement des conducteurs en cuivre.
3. Ne convient pas aux installations de plus de 150 volt a la terre.

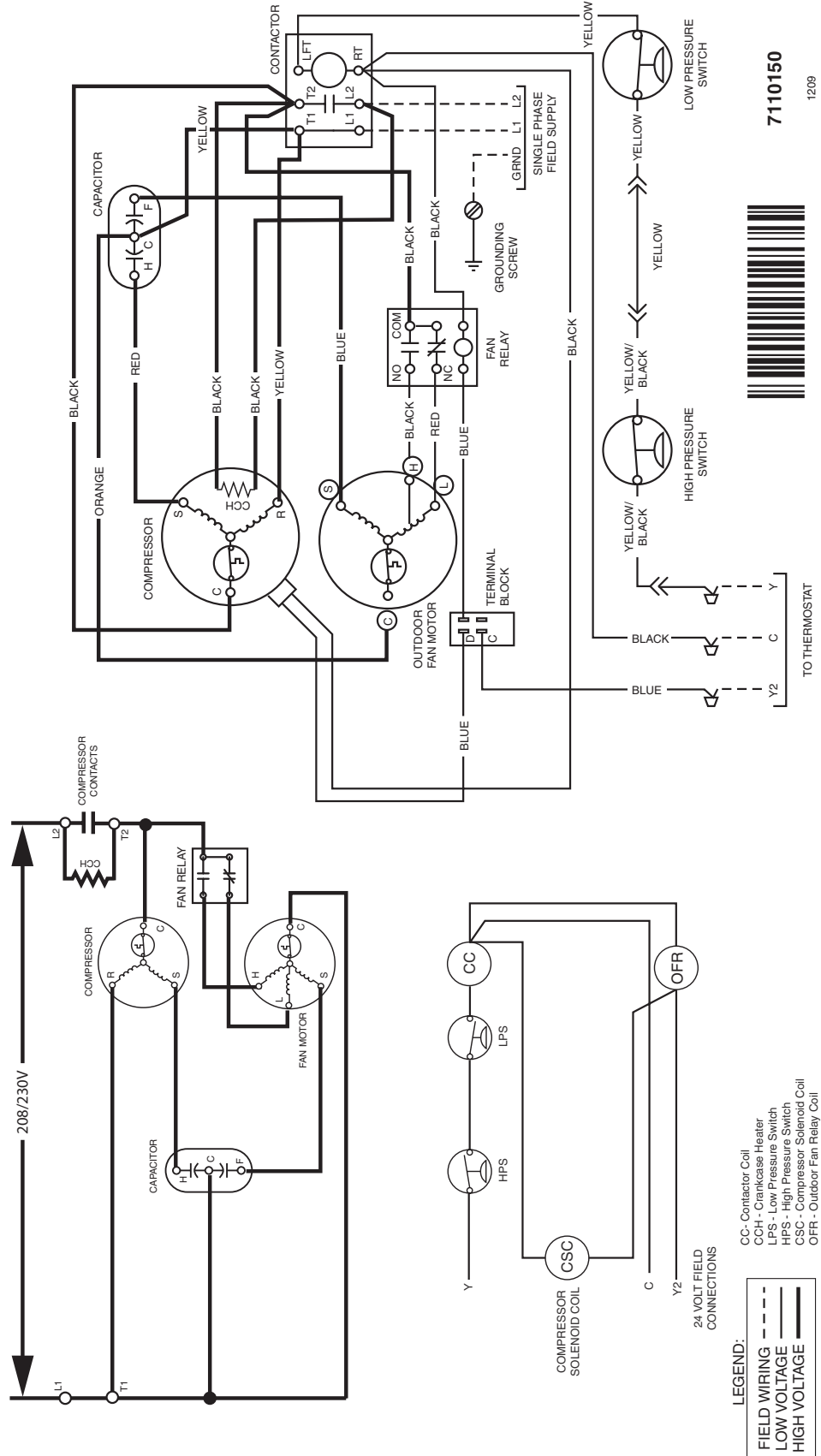

7110150

1209

Figure 7. W.D. for 3 Ton Models without CoreSense™

WIRING DIAGRAM

Two Stage Split Air Conditioner (Outdoor Section) With Two Speed Outdoor Fan Motor

208/230V

Single Phase / 60 Hz.

Status LED	Status LED Description	Lockout Level	Lockout Indication
Normal Run: Solid Green	Normal Operation, no trip	N/A	N/A
Code 1: Yellow Flash 1	Compressor running extremely long run cycle. (disabled in HP mode.)	N/A	N/A
Code 2: Yellow Flash 2	Compressor Pressure Trip. Disch. or suct. pressure out of limits or compressor overloaded.	4 cons. 10x total	Red: Flash 2
Code 3: Yellow Flash 3	Short Cycling. Compressor is running only briefly.	4 cons. 10x total	Red: Flash 3
Code 4: Yellow Flash 4	Locked Rotor.	10 consecutive	Red: Flash 4
Code 5: Yellow Flash 5	Compressor Moderate Run. Compressor runs > 15min, then trips > 7min.	4 cons. 10x total	Red: Flash 5
Code 6: Red Flash 6	Open Start Circuit. Current only in run circuit.	1 Occurrence	Red: Flash 6
Code 7: Red Flash 7	Welded Contactor. Compressor always runs.	N/A	Red: Flash 7
Code 8: Yellow Flash 8	Low Voltage. Control circuit < 17 VAC.	N/A	N/A
Code 9: Red Flash 9	Over Current Protection. PROT terminal has > 2A input for more than 40ms	1 Occurrence	Red: Flash 10
Code 10: Red Flash 10	ROUTED THIS WIRE THROUGH "C" OPENING IN CORESENSE MODULE	N/A	N/A

- NOTES:**
1. Disconnect all power before servicing.
 2. For supply connections use copper conductors only.
 3. Not suitable on systems that exceed 150 volts to ground.
 4. For replacement wires use conductors suitable for 105
 5. For ampacities and overcurrent protection, see unit rating plate.
 6. Connect to 24 vac/40va/class 2 circuit. See furnace/airhandler installation instructions for control circuit and optional relay/transformer kits.
 7. Couper le courant avant de faire leretien.
 8. Employez uniquement des conducteurs en cuivre.
 9. Ne convient pas aux installations de plus de 150 volt a la terre.

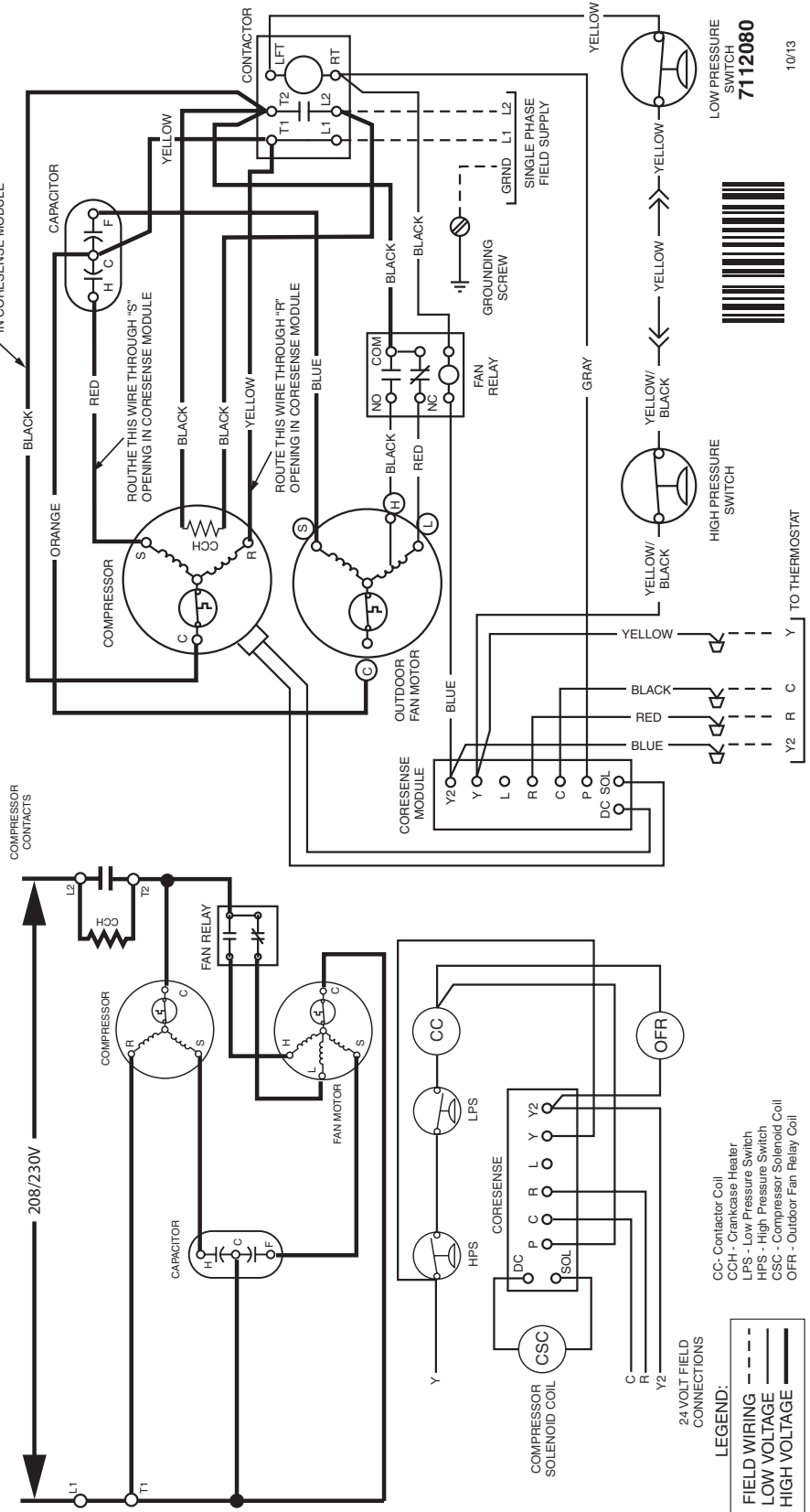

Figure 8. W.D. for 3 Ton Models with CoreSense™

LOW PRESSURE SWITCH
7112080



10113

TO THERMOSTAT
Y2 R C Y

24 VOLT FIELD CONNECTIONS

- LEGEND:**
- FIELD WIRING
 - LOW VOLTAGE
 - HIGH VOLTAGE

- CC - Contactor Coil
- CCH - Crankcase Heater
- LPS - Low Pressure Switch
- HPS - High Pressure Switch
- CSC - Compressor Solenoid Coil
- OFF - Outdoor Fan Relay Coil

WIRING DIAGRAM

Two Stage Split System Air Conditioner (Outdoor Section) With ECM Outdoor Motor

208/230V

Single Phase / 60 Hz.

NOTES:

1. Disconnect all power before servicing.
2. For supply connections use copper conductors only.
3. Not suitable on systems that exceed 150 volts to ground.
4. For replacement wires use conductors suitable for 105 °C
5. For ampacities and overcurrent protection, see unit rating plate.
6. Connect to 24 vac/40va/class 2 circuit. See furnace/airhandler installation instructions for control circuit and optional relay/transformer kits.

1. Couper le courant avant de faire leretien.
2. Employez uniquement des conducteurs en cuivre.
3. Ne convient pas aux installations de plus de 150 volt a la terre.

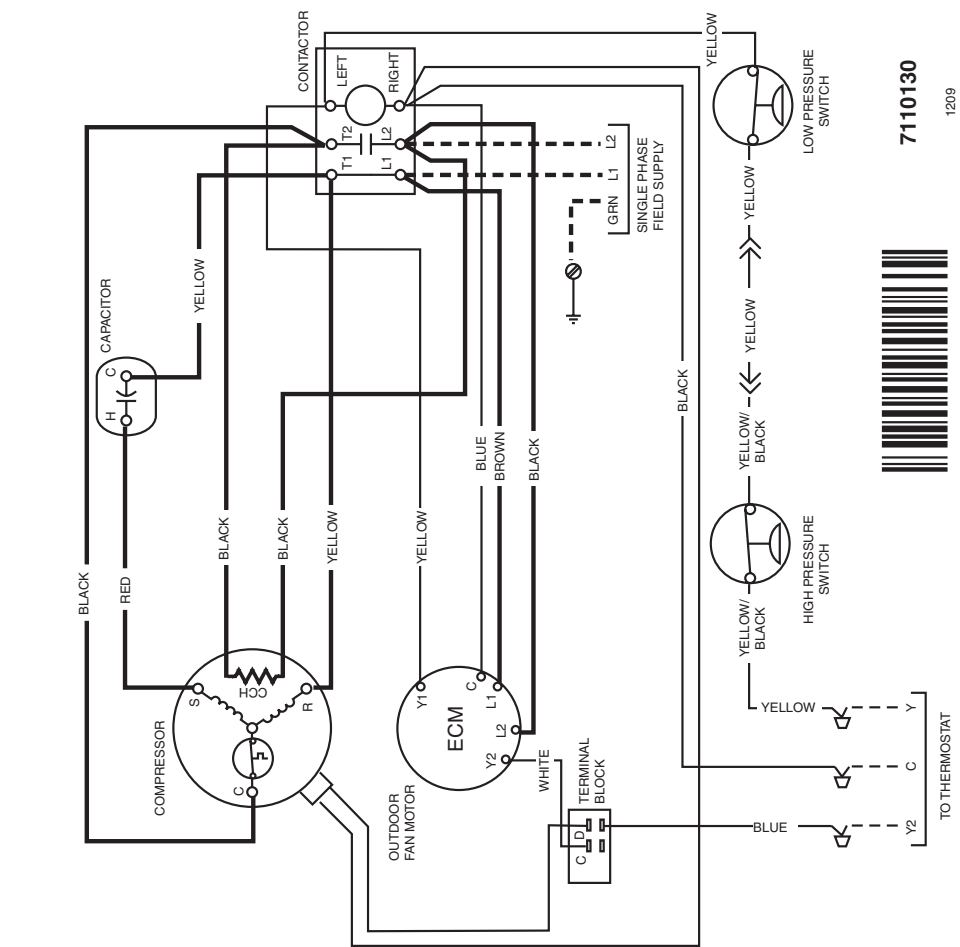
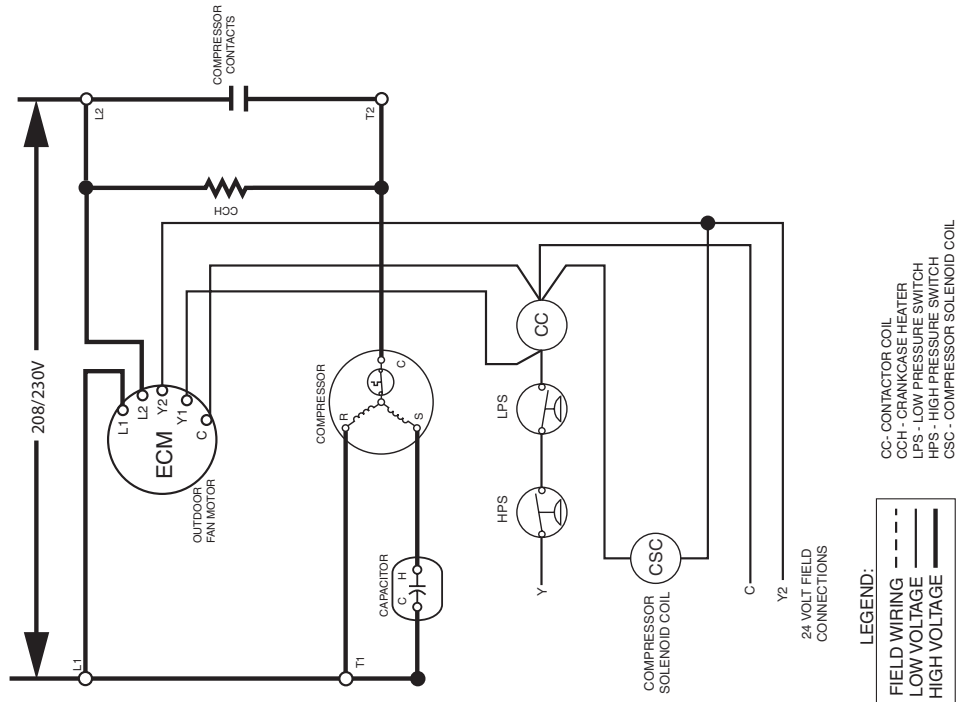

7110130

1209

Figure 9. W.D. for 4 & 5 Ton Models without CoreSense™

WIRING DIAGRAM

Two Stage Split System Air Conditioner (Outdoor Section) with ECM Outdoor Motor

208/230V

Single Phase / 60 Hz.

Status LED	Status LED Description	Lockout Level	Lockout Indication
Normal Run; Solid Green	Normal Operation, no trip	N/A	N/A
Code 1; Yellow Flash 1	Compressor running extremely long run cycle, (disabled in HP mode)	N/A	N/A
Code 2; Yellow Flash 2	Compressor Pressure Trip. Disch. or suct. pressure out of limits or compressor overloaded.	4 cons, 10x total	Red; Flash 2
Code 3; Yellow Flash 3	Short Cycling. Compressor is running only briefly.	4 cons, 10x total	Red; Flash 3
Code 4; Yellow Flash 4	Locked Rotor.	10 consecutive	Red; Flash 4
Code 5; Yellow Flash 5	Compressor Moderate Run. Compressor runs >15min, then trips >7min.	4 cons, 10x total	Red; Flash 5
Code 6; Red Flash 6	Open Start Circuit. Current only in run circuit.	1 Occurrence	Red; Flash 6
Code 7; Red Flash 7	Open Start Circuit. Current only in start circuit.	1 Occurrence	Red; Flash 7
Code 8; Yellow Flash 8	Welded Contactor. Compressor always runs.	N/A	N/A
Code 9; Yellow Flash 9	Low Voltage. Control circuit <17 VAC.	N/A	N/A
Code 10; Red Flash 10	Over Current Protection. PROT terminal has >2A input for more than 40ms	1 Occurrence	Red; Flash 10

- NOTES:**
1. Disconnect all power before servicing.
 2. For supply connections use copper conductors only.
 3. Not suitable on systems that exceed 150 volts to ground.
 4. For replacement wires use conductors suitable for 105 °C
 5. For ampacities and overcurrent protection, see unit rating plate.
 6. Connect to 24 vac/40va/class 2 circuit. See furnace/airhandler installation instructions for control circuit and optional relay/transformer kits.
 7. Couper le courant avant de faire l'entretien.
 8. Employez uniquement des conducteurs en cuivre.
 9. Ne convient pas aux installations de plus de 150 volt a la terre.

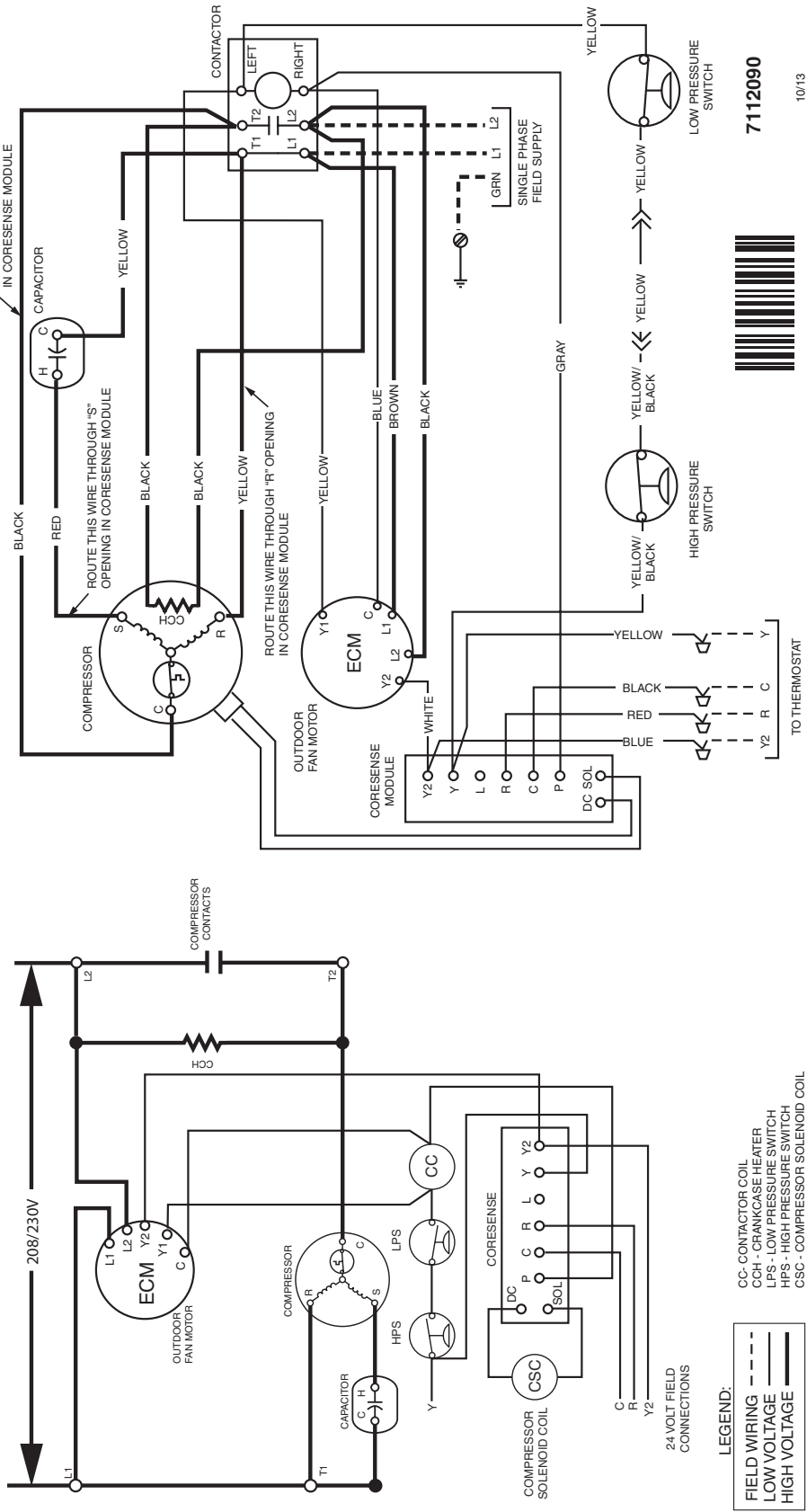

Figure 10. W.D. for 4 & 5 Ton Models with CoreSense™

CORESENSE TROUBLESHOOTING

STATUS LED	STATUS LED DESCRIPTION	STATUS LED TROUBLESHOOTING INFORMATION
Solid Green "RUN"	Module has power and operating normally	Supply voltage is present at module terminals
Solid Red "TRIP"	Thermostat demand signal Y is present, but the compressor is not running	<ol style="list-style-type: none"> 1. Compressor protector is open <ul style="list-style-type: none"> • Check for high head pressure • Check compressor supply voltage 2. Outdoor unit power disconnect is open 3. Compressor circuit breaker or fuse(s) is open 4. Broken wire or connector is not making contact 5. High pressure switch open if present in system 6. Compressor contactor has failed open
ALERT Flash Codes		
Yellow "ALERT" Flash Code 1	Long Run Time Low Refrigerant Charge Compressor is running extremely long run cycles	<ol style="list-style-type: none"> 1. Low refrigerant charge 2. Evaporator blower is not running <ul style="list-style-type: none"> • Check blower relay coil and contacts • Check blower motor capacitor • Check blower motor for failure or blockage • Check evaporator blower wiring and connectors • Check indoor blower control board • Check thermostat wiring for open circuit 3. Evaporator coil is frozen <ul style="list-style-type: none"> • Check for low suction pressure • Check for excessively low thermostat setting • Check evaporator airflow (coil blockages or return air filter) • Check ductwork or registers for blockage 4. Faulty metering device <ul style="list-style-type: none"> • Check TXV bulb installation (size, location and contact) • Check if TXV/fixed orifice is stuck closed or defective 5. Liquid line restriction (filter drier blocked if present in system) 6. Thermostat is malfunctioning <ul style="list-style-type: none"> • Check thermostat sub-base or wiring for short circuit • Check thermostat installation (location, level)
Yellow "ALERT" Flash Code 2	Compressor (Pressure) Trip High Refrigerant Charge Discharge pressure out of limits or compressor overloaded	<ol style="list-style-type: none"> 1. Condenser fan is not running <ul style="list-style-type: none"> • Check fan capacitor • Check fan wiring and connectors • Check fan motor for failure or blockage 2. High head pressure <ul style="list-style-type: none"> • Check high pressure switch if present in system • Check if system is overcharged with refrigerant • Check for non-condensable in system 3. Condenser coil poor air circulation (dirty, blocked, damaged) 4. Return air duct has substantial leakage
Yellow "ALERT" Flash Code 3	Pressure Switch Cycling Compressor is running only briefly due to pressure switch cycling	<ol style="list-style-type: none"> 1. Time delay relay or control board defective 2. If high pressure switch present go to Flash Code 2 information
Yellow "ALERT" Flash Code 4	Locked Rotor	<ol style="list-style-type: none"> 1. Run capacitor has failed 2. Low line voltage (contact utility if voltage at disconnect is low) <ul style="list-style-type: none"> • Check wiring connections 3. Excessive liquid refrigerant in compressor 4. Compressor bearings are seized <ul style="list-style-type: none"> • Measure compressor oil level
Yellow "ALERT" Flash Code 5	Compressor (Moderate Run) Trip	<ol style="list-style-type: none"> 1. Evaporator blower is not running <ul style="list-style-type: none"> • Check blower relay coil and contacts • Check blower motor capacitor • Check blower motor for failure or blockage • Check evaporator blower wiring and connectors • Check indoor blower control board • Check thermostat wiring for open circuit 2. Faulty metering device <ul style="list-style-type: none"> • Check TXV bulb installation (size, location and contact) • Check if TXV/fixed orifice is stuck closed or defective 3. Condenser coil poor air circulation (dirty, blocked, damaged) 4. Low refrigerant charge

Table 3. CoreSense™ Diagnostics & Troubleshooting

CORESENSE TROUBLESHOOTING - CONTINUED

STATUS LED	STATUS LED DESCRIPTION	STATUS LED TROUBLESHOOTING INFORMATION
Yellow "ALERT" Flash Code 8	Welded Contactor Compressor always runs	<ol style="list-style-type: none"> 1. Compressor contactor has failed closed 2. Thermostat demand signal not connected to module
Yellow "ALERT" Flash Code 9	Low Supply Voltage Voltage below 18V	<ol style="list-style-type: none"> 1. Control Circuit transformer is overloaded 2. Low line voltage (contact utility if voltage at disconnect is low)
LOCKOUT Flash Codes		
Red "LOCKOUT" Flash Code 2 Yellow Off	Compressor (Pressure) Trip Compressor is locked out after 4 consecutive or 10 total compressor (pressure) trip events	<ol style="list-style-type: none"> 1. Condenser fan is not running <ul style="list-style-type: none"> • Check fan capacitor • Check fan wiring and connectors • Check fan motor for failure or blockage 2. High head pressure <ul style="list-style-type: none"> • Check high pressure switch if present in system • Check if system is overcharged with refrigerant • Check for non-condensable in system 3. Condenser coil poor air circulation (dirty, blocked, damaged) 4. Return air duct has substantial leakage
Red "LOCKOUT" Flash Code 3 Yellow Off	Pressure Switch Cycling Compressor is locked out after 4 consecutive or 10 total pressure cycling events	<ol style="list-style-type: none"> 1. Time delay relay or control board defective 2. If high pressure switch present go to Flash Code 2 information
Red "LOCKOUT" Flash Code 4 Yellow Off	Locked Rotor Compressor is locked out after 10 consecutive locked rotor events	<ol style="list-style-type: none"> 1. Run capacitor has failed 2. Low line voltage (contact utility if voltage at disconnect is low) <ul style="list-style-type: none"> • Check wiring connections 3. Excessive liquid refrigerant in compressor 4. Compressor bearings are seized <ul style="list-style-type: none"> • Measure compressor oil level
Red "LOCKOUT" Flash Code 5 Yellow Off	Compressor (Moderate Run) Trip	<ol style="list-style-type: none"> 1. Evaporator blower is not running <ul style="list-style-type: none"> • Check blower relay coil and contacts • Check blower motor capacitor • Check blower motor for failure or blockage • Check evaporator blower wiring and connectors • Check indoor blower control board • Check thermostat wiring for open circuit 2. Faulty metering device <ul style="list-style-type: none"> • Check TXV bulb installation (size, location and contact) • Check if TXV/fixed orifice is stuck closed or defective 3. Condenser coil poor air circulation (dirty, blocked, damaged) 4. Low refrigerant charge
Red "LOCKOUT" Flash Code 6 Yellow Off	Open Start Circuit Current only in run circuit	<ol style="list-style-type: none"> 1. Run capacitor has failed 2. Open circuit in compressor start wiring or connections <ul style="list-style-type: none"> • Check wiring and connectors between supply and the compressor "S" terminal 3. Compressor start winding is damaged <ul style="list-style-type: none"> • Check compressor motor winding resistance
Red "LOCKOUT" Flash Code 7 Yellow Off	Open Run Circuit Current only in start circuit	<ol style="list-style-type: none"> 1. Open circuit in compressor run wiring or connections <ul style="list-style-type: none"> • Check wiring and connectors between supply and the compressor "R" terminal. Confirm proper wire routing as shown in Figure 3, (page 6). 2. Compressor run winding is damaged <ul style="list-style-type: none"> • Check compressor motor winding resistance
Red "LOCKOUT" Flash Code 10	Over Current Protection Current to PROT is greater than 2A mps	<ol style="list-style-type: none"> 1. Check for contactor shorted to ground 2. Check for mis-wiring to the PROT terminal

* Flash code number corresponds to a number of LED flashes, followed by a pause and then repeated. Trip and alert LED's flashing at same time means control circuit voltage is too low for operation.

Table 3. CoreSense™ Diagnostics & Troubleshooting - Continued

INSTALLATION CHECKLIST

INSTALLATION ADDRESS:		
CITY _____	STATE _____	
UNIT MODEL # _____		
UNIT SERIAL # _____		
Unit Installed Minimum clearances per Figure 1, (page 3) ?	YES	NO
INSTALLER NAME:		
CITY _____	STATE _____	

REFRIGERATION SYSTEM:		
Was unit given 24 hr warm up period for crankcase heaters?	YES	NO
Stage-1 Liquid Pressure (high side) _____		
Stage-1 Suction Pressure (low side) _____		
Has the owner's information been reviewed with the customer?	YES	NO
Has the Literature Package been left with the unit?	YES	NO

ELECTRICAL SYSTEM		
Electrical connections tight?	YES	NO
Line voltage polarity correct?	YES	NO
Rated Voltage: _____ VOLTS		
L1-L2 Volts: _____ VOLTS		
L1-L3 Volts: _____ VOLTS		
L2-L3 Volts: _____ VOLTS		
Avg. Volts: _____ VOLTS		
Max. deviation of voltage from avg. volts: _____ VOLTS		
% Volt imbalance: _____ VOLTS		
Blower Motor HP: _____ Sheave Setting _____ # Turns		
Has the thermostat been calibrated?	YES	NO
Is the thermostat level?	YES	NO
Is the heat anticipator setting correct? (If Applicable)	YES	NO

REPLACEMENT PARTS

Replacement parts are available through your distributor distributors. Please have the complete model and serial number of the unit when ordering replacement parts.

Electrical:

- Capacitors
- Compressors
- Contactors
- Pressure Switches
- Relays
- Temperature Limit Switches
- Thermostats
- Time Delay Relays
- Transformers

Motors:

- Blower Motor
- Fan Motor

Components:

- Blower Assembly
- Cabinet Panels
- Expansion Valves
- Fan Grille
- Filter/Driers



NORDYNE
COMPLETE COMFORT. GENUINE VALUE.

Specifications & illustrations subject to change without notice or incurring obligations (03/14).



7097130 (Replaces 7094330)